

Global PV Storage Insights

Average solar diesel hybrid storage price per 100kW in Yemen



Overview

In this study, it is of great interest to evaluate the sensitivity of the most preferred power systems (Case IV and Case V) against the variability of three key parameters: the diesel price, the average global solar (AGS) radiation and the average wind speed (AWS).

In this study, it is of great interest to evaluate the sensitivity of the most preferred power systems (Case IV and Case V) against the variability of three key parameters: the diesel price, the average global solar (AGS) radiation and the average wind speed (AWS).

There is a significant potential in the Arab region for introducing solar PV technologies into existing diesel-based of-grid systems. Estimating this relevant stakeholders. The following report is an earnest attempt to shed and Yemen. These countries have significant of-grid diesel usage for water.

This report uses own calculations, new household surveys, and extensive literature research to document Yemen's solar revolution. While the report identifies central drivers for the diffusion of solar energy, it also discovers critical barriers: Since 2017, growth in the solar sector has been.

The Yemen Energy Storage Market accounted for \$XX Billion in 2023 and is anticipated to reach \$XX Billion by 2030, registering a CAGR of XX% from 2024 to 2030. Masdar will erect Global's first substantial solar power facility. near order to construct a 120 MW solar facility near Aden, Masdar, and.

Secondly, this study proposes the method of optimizing different configurations of off-grid hybrid (solar/wind/diesel engine) energy systems for electrifying various consumers in Taiz province, Yemen under three scenarios of energy strategies. The objective function is to seek the most optimal.

In 2019, RCREEE and the United Nations Office for Project Services (UNOPS) launched a new project for the assessment of solar PV market in Yemen. The project provides updates on the status of solar PV market including the local supply chain of solar PV products, the available technical.

We designed and developed a unique, low-cost solar microgrid solution that uses our 3x6 approach for longer term sustainability. 1 Our solar microgrids offer an alternative, clean and renewable energy source that allows rural homes the ability to afford uninterrupted electricity for hours. Before the.

Average solar diesel hybrid storage price per 100kW in Yemen

Home Energy Storage (Stackble system)



Diesel to Solar Transformation

List of figures Figure 1 - International Brent prices and average diesel price in Arab countries
 Figure 2 - Three problem areas inhibiting market development of of-grid solar energy ...

Commercial Battery Storage Costs: A Comprehensive Breakdown

Commercial Battery Storage Costs: A Comprehensive Breakdown Energy storage technologies are becoming essential tools for businesses seeking to improve energy efficiency and ...



Assessment of environmental and economic perspectives for ...

...

In this study, it is of great interest to evaluate the sensitivity of the most preferred power systems (Case IV and Case V) against the variability of three key parameters: the diesel ...

Solar/Wind/Diesel Hybrid Energy System with Battery ...

This paper presents solar/wind/diesel hybrid energy system with battery storage. More than

70% of rural population in Myanmar still has difficulty been accessing electricity?



Solar Diesel Hybrid Controller: Minimize diesel cost

Our solar diesel hybrid controller curtails the right amount of solar power to enable a maximum PV production, while ensuring zero export to the grid, thus avoiding penalties from the grid operator.

Solar Installed System Cost Analysis , Solar Market ...

Solar Installed System Cost Analysis NREL analyzes the total costs associated with installing photovoltaic (PV) systems for residential rooftop, commercial rooftop, and utility-scale ground-mount systems. This work has ...

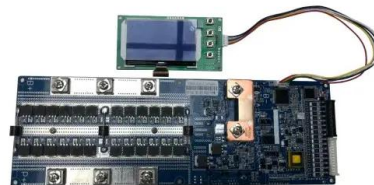

Outdoor Power Supply Installation in Yemen Challenges ...

Summary: This guide explores the growing demand for outdoor power supply systems in Yemen, analyzing installation challenges, renewable energy integration, and cost-effective strategies. ...

UNDP Yemen: Fully Solar Powered

With a number of solar panels already in place in both Sana'a and Aden offices, UNDP made the decision to go completely 100 per cent solar powered in Sana'a. Construction soon began to install hundreds of solar ...



Yemen s solar revolution: Developments, challenges, ...

This report documents the development of solar energy in Yemen. It uses own calculations, recent household surveys, and extensive literature research, in addition to numerous ...

ABLE PAK 102KWH Hybrid Battery Power System ...

The Able PAK100-100 is an intelligent, scalable, fully integrated, plug and play, hybrid battery power station. A huge 100kW 415V output (250kW peak) and 102kWh storage capacity.

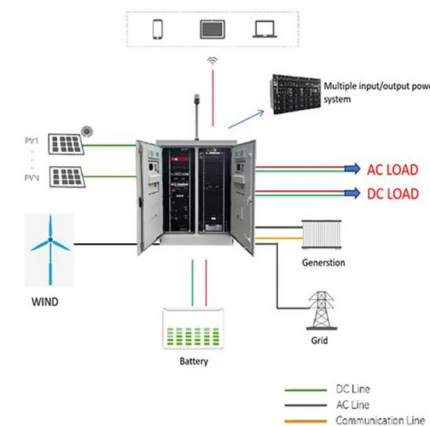

100kW Solar System: Price, Load Capacity, How Big, ...

How Much Will a 100kW Solar System Save? Installing a 100kW solar system can lead to significant cost savings over time. On average, a 100kW solar system can save up to \$31,025 per year. Over the 25-year lifetime of the ...

Solar Diesel Hybrid Controller: Minimize diesel cost

Our solar diesel hybrid controller curtails the right amount of solar power to enable a maximum PV production, while ensuring zero export to the grid, thus avoiding penalties from the grid operator.



Potential Techno-Economic Feasibility of Hybrid ...

Secondly, this study proposes the method of optimizing different configurations of off-grid hybrid (solar/wind/diesel engine) energy systems for electrifying various consumers in Taiz province, Yemen under ...

Diesel to Solar Transformation

Diesel-based mini-grids can be retrofitted with solar PV to create solar-diesel hybrid systems. Some resorts in Egypt have begun experimenting with this solution in recent years as a result ...



Design and Analysis of PV-DIESEL Hybrid Power System Case ...

The textbook presents a brief outline of the basic engineering in designing and analysing PV diesel hybrid power systems. The study has been taken from the point of view of ...

Use of a Hybrid Wind--Solar--Diesel--Battery ...

The results showed that the simultaneous use of wind and solar systems with a converter and a backup system comprised of a diesel generator and batteries will be the most economic option, offering



Energy Storage Systems

The SunGiga from Jinko Solar is a liquid-cooled energy storage system for commercial and industrial use, with capacities ranging from 200 kilowatts per hour to 2 megawatts per hour. It is designed to meet the needs of self-consumption

...

Energy Storage Systems

The SunGiga from Jinko Solar is a liquid-cooled energy storage system for commercial and industrial use, with capacities ranging from 200 kilowatts per hour to 2 megawatts per hour. It is

...



100KW 150KW 200KW Solar System Cost

PVMars lists the costs of 100kW, 150kW, and 200kW solar plants here (Gel battery design). If you want the price of a lithium battery design, please click on the product page of the corresponding model to find out.

The Complete Off Grid Solar System Sizing Calculator

An off-grid solar system's size depends on factors such as your daily energy consumption, local sunlight availability, chosen equipment, the appliances that



100kVA 100kW Solar Power Plant And Price

Flexible, Scalable Design For Efficient 100kVA 100kW Solar Power Plant. With Lithium-ion Battery Off Grid Solar System For A Factory, Hotel, or House Communities.

Yemen Energy Storage Market 2024-2030

Energy storage systems make it possible to balance the supply and demand of energy, increase grid stability, better integrate erratic renewable energy sources, and offer backup power in case of emergencies.



Potential Techno-Economic Feasibility of Hybrid Energy ...

Secondly, this study proposes the method of optimizing different configurations of off-grid hybrid (solar/wind/diesel engine) energy systems for electrifying various consumers in Taiz province, ...

Assessment of environmental and economic perspectives for ...

...

In Yemen's Shafail, where solar energy resources are more plentiful, a combination of photovoltaic, wind, and diesel energy systems saves 45% of the energy cost ...



The Solar Diesel Hybrid System

A photovoltaic (solar) diesel hybrid system works by ensuring that the main energy source is used in a way that is both efficient and environmentally friendly. How does a ...



DESIGN, PERFORMANCE EVALUATION AND ...

The Solar PV-Grid-Diesel Hybrid Power System can be used to overcome the inconvenience due to unavailability of power to a great extent. Integration of solar PV systems with the diesel plants is being disseminated worldwide to reduce ...



100kW Solar System Price - On grid, Off grid and Hybrid

100kW Solar system cost in India. Buy 100kW On-grid, Off-grid and Hybrid solar systems at best price with subsidy and battery backup.

MINISTRY OF ELECTRICITY AND ENERGY THE ...

Figure 4-4: Stand alone wind hybrid system An option for large villages in Yemen (with more than 400 households) is the installation of isolated stand alone systems including one or more wind ...



Report on Solar PV-Diesel Hybrid Mini Cold Storage for ...

Here we propose for a cold storage that will mainly run during the day time by consuming power from the roof top solar PV panels. The usual run time of a cold storage does not exceed 25%. ...

UNDP's Solar Hybrid Solutions Result in More Robust ...

The United Nations Development Programme (UNDP) and partners inaugurated a solar hybrid system that will provide an uninterrupted power supply to the central COVID-19 Isolation Unit in Seiyun, Hadramout. A ...



Hybrid wind and solar power systems Yemen

The aim of this study is to analyze wind speed and solar radiation data of Rafha, KSA, and to assess the technical and economic potential of hybrid wind-PV-diesel power systems to meet

Feasibility Study for a Hybrid Power Plant (PV-Wind-Diesel-Storage)

In this work, we present a feasibility study for a new hybrid power plant (PV-Wind-Diesel-Storage) directly connected to the electrical grid. Several simulations are ...



Contact Us

For catalog requests, pricing, or partnerships, please visit:
<https://naturesnursery.co.za>