

## Global PV Storage Insights

# Large scale battery storage cost vs benefit calculation in Norway



## Overview

---

The study further presents a methodology to calculate the optimal BTM-BSS size for the system, based on capital costs, multi-year electricity tariffs and energy demand.

The study further presents a methodology to calculate the optimal BTM-BSS size for the system, based on capital costs, multi-year electricity tariffs and energy demand.

Although recent research literature proposes a wide range of methods and models for Cost-Benefit Analysis (CBA) of BESS for grid applications, these are to a little extent applied in practice. For the research-based methods to be suitable for grid planning, they should handle timing of.

Battery storage is a technology that enables power system operators and utilities to store energy for later use. A battery energy storage system (BESS) is an electrochemical device that charges (or collects energy) from the grid or a power plant and then discharges that energy at a later time to.

n the process of developing a national battery strategy. The basis for this work is a strong increase in the demand for more sustainable batteries for various purposes, both globally and in Europe, and the fact that Norway is considered to be in a good position to take arket share in several parts.

Recent industry analysis reveals that lithium-ion battery storage systems now average €300-400 per kilowatt-hour installed, with projections indicating a further 40% cost reduction by 2030. For utility operators and project developers, these economics reshape the fundamental calculations of grid.

Although recent research literature proposes a wide range of methods and models for Cost-Benefit Analysis (CBA) of BESS for grid applications, these are to a little extent applied in practice. For the research-based methods to be suitable for grid planning, they should handle timing of. How much does a battery cost in Norway?

ccount for around 10% of the value of Norwegian exports. In a few years, the

price of battery energy storage systems (BESS) will typically be between USD 150/kWh and USD 250/kWh (currently USD 300–500/kWh), which means that if 25% of the Norwegian battery cell production went to BESS for domestic/export purposes.

Why is the battery value chain important in Norway?

Market share in several parts of the battery value chain. The battery value chain has the potential to become a major new, profitable industry in Norway, giving us a chance to contribute to emission reduction, create green jobs and aid the transition.

What is a large-scale battery energy storage system (BESS)?

Large-scale Battery Energy Storage Systems (BESS) play a crucial role in the future of power system operations. The recent price decrease in stationary storage.

What is the energy need for battery production in Norway?

Engaging and aligning the project with relevant stakeholders. Local resident Norwegian Environment Agency, 21 March 2022 Energy needs The energy needed for battery production in Norway is uncertain despite the fact that production capacity is normally measured by.

Is BTM-BSS economically viable for large electricity consumers in Norway?

BTM-BSS is economically viable for large electricity consumers in Norway. Electricity can be a significant cost for large commercial/industrial consumers, and optimal dispatch of behind-the-meter battery storage systems (BTM-BSS) have the potential to reduce these costs.

How much does battery storage cost in Europe?

The landscape of utility-scale battery storage costs in Europe continues to evolve rapidly, driven by technological advancements and increasing demand for renewable energy integration. As we've explored, the current costs range from €250 to €400 per kWh, with a clear downward trajectory expected in the coming years.

## Large scale battery storage cost vs benefit calculation in Norway



### Study proves the economic benefits of large-scale ...

Large batteries benefit the economy and society far more than they cost. This is the key finding of a recent study by the international economic consultancy Frontier Economics (FE) on the "Potential of large-scale battery ...

### Battery energy storage system

A battery energy storage system (BESS), battery storage power station, battery energy grid storage (BEGS) or battery grid storage is a type of energy storage technology that uses a group of batteries in the grid to store electrical energy.



### The Role of Large-Scale Energy Storage Systems: ...

Location of any large-scale energy storage system, as well as energy production facilities, must take into account health and environmental impact. This article explores large-scale energy storage options, notable ...

### Study proves the economic benefits of large-scale batteries

Large batteries benefit the economy and society far more than they cost. This is the key finding of

a recent study by the international economic consultancy Frontier Economics ...



## Utility-Scale Battery Storage: What You Need To Know

With the declining cost of energy storage technology, solar batteries are an increasingly popular addition to solar installations. It's not just residential and commercial solar shoppers that benefit from installing energy ...

## Cost and Performance of Grid Scale Energy Storage Options

Abstract Energy storage systems provide an important solution for improving the reliability of electricity networks due to challenges of integrating intermittent electricity from variable ...



## Utility-Scale Battery Storage , Electricity , 2022 , ATB

The 2022 ATB represents cost and performance for battery storage across a range of durations (2-10 hours). It represents lithium-ion batteries (LIBs)--focused primarily on nickel manganese cobalt (NMC) and lithium iron ...

## Life-cycle assessment of gravity energy storage systems for large-scale

Moreover, a life cycle costs and levelized cost of electricity delivered by this energy storage are analyzed to provide expert, power producers, and grid operators insight ...



Application scenarios of energy storage battery products



## What are the main cost components of utility-scale battery storage

Overall, utility-scale battery storage costs are a composite of energy capacity-related costs (battery cells, BOS energy components) denoted mostly in \$/kWh, power ...

## Understanding Utility-Scale vs. Residential Battery Storage

Utility-scale battery systems are designed for large-scale energy storage to support the electric grid, requiring high initial investments but offering significant long-term savings and benefits.

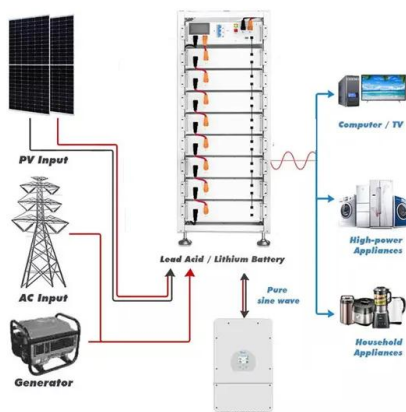
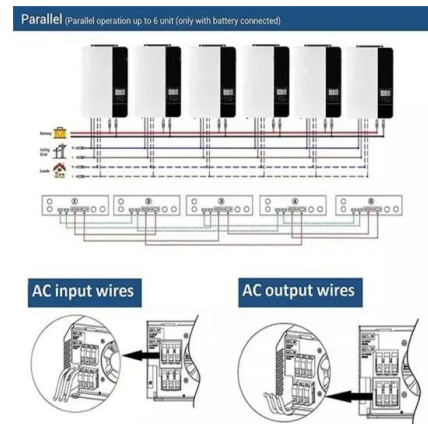

## A comparative overview of large-scale battery systems for ...

In this work, an overview of the different types of batteries used for large-scale electricity storage is carried out. In particular, the current operational large-scale battery energy ...

## Historical and prospective lithium-ion battery cost trajectories ...

However, predictions for LiB cost trajectory are challenging since a large number of factors, such as market demand [20], essential material prices [18], technological ...



### GRADE A BATTERY

LiFePO4 battery will not burn when overcharged, over discharged, overcurrent or short circuited and can withstand high temperatures without decomposition.



## Battery energy storage systems , BESS

Battery energy storage (BESS) offer highly efficient and cost-effective energy storage solutions. BESS can be used to balance the electric grid, provide backup power and improve grid stability.

## Cost Projections for Utility-Scale Battery Storage: 2021 ...

Executive Summary In this work we describe the development of cost and performance projections for utility-scale lithium-ion battery systems, with a focus on 4-hour duration ...

18650<sup>3.7V</sup>  
 Li-ion  
RECHARGEABLE BATTERY  
**2000mAh**



18650<sup>3.7V</sup>  
 Li-ion  
RECHARGEABLE BATTERY  
**2000mAh**



## Battery cost forecasting: a review of methods and results with an

Within this transformation, battery costs are considered a main hurdle for the market-breakthrough of battery-powered products. Encouraged by this, various studies have ...

## Battery Energy Storage Systems: Benefits, Types, ...

Explore how Battery Energy Storage Systems (BESS) store energy, support solar power, and reduce costs. Learn benefits, types, and applications for a sustainable future.



### Paper Title (use style: paper title)

To perform the CBA it is necessary to calculate the operational benefits of BESS for each planning alternative by taking into account short-term variability in demand and power output ...

## The Ultimate Guide to Battery Energy Storage ...

Battery Energy Storage Systems (BESS) have become a cornerstone technology in the pursuit of sustainable and efficient energy solutions. This detailed guide offers an extensive exploration of BESS, ...



## A COST-BENEFIT ANALYSIS OF LARGE-SCALE BATTERY ...

This paper presents an analysis of the potential profits yielded from the operation of a large-scale battery in the Finnish Frequency Containment Reserves for Normal Operations market. ...

## Costs of 1 MW Battery Storage Systems 1 MW / 1 ...

Explore the intricacies of 1 MW battery storage system costs, as we delve into the variables that influence pricing, the importance of energy storage, and the advancements shaping the future of sustainable energy ...

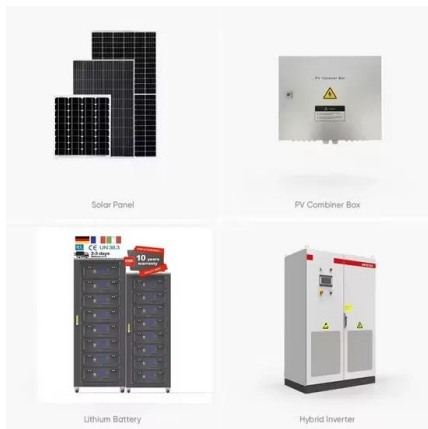

### Figure 1. Recent & projected costs of key grid

Meanwhile, the costs of pumped hydro storage are expected to remain relatively stable in the coming years, maintaining its position as the cheapest form - in terms of \$/kWh - ...

## Real Cost Behind Grid-Scale Battery Storage: 2024 ...

The dramatic scaling of battery manufacturing capacity across Europe and globally has been a primary driver in reducing utility-scale storage costs. Since 2010, battery pack prices have declined by approximately 89%, ...

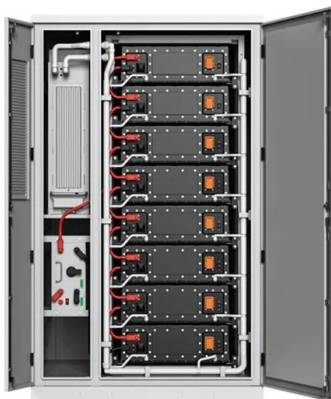

### Enervis BESS Index: What revenues can and could ...

With the large-scale battery storage market in Germany on the cusp of a rapid expansion, consultancy Enervis is examining how revenues have evolved recently and what the future holds.

## Battery cost forecasting: a review of methods and ...

Within this transformation, battery costs are considered a main hurdle for the market-breakthrough of battery-powered products. Encouraged by this, various studies have been published attempting to predict these, ...



## Grid-scale battery costs: \$/kW or \$/kWh?

Grid-scale battery costs can be measured in \$/kW or \$/kWh terms. Thinking in kW terms is more helpful for modelling grid resiliency. A good rule of thumb is that grid-scale ...



## A COST-BENEFIT ANALYSIS OF LARGE-SCALE BATTERY ENERGY STORAGE ...

Large-scale Battery Energy Storage Systems (BESS) play a crucial role in the future of power system operations. The recent price decrease in stationary storage systems has enabled novel ...



## How much does it cost to build a battery energy ...

How much does it cost to build a battery in 2024? Modo Energy's industry survey reveals key Capex, O& M, and connection cost benchmarks for BESS projects.



## BESS Costs Analysis: Understanding the True Costs of Battery

Battery Energy Storage Systems (BESS) are becoming essential in the shift towards renewable energy, providing solutions for grid stability, energy management, and ...



## On-grid batteries for large-scale energy storage: Challenges and

The promise of large-scale batteries Poor cost-effectiveness has been a major problem for electricity bulk battery storage systems. 7 Now, however, the price of battery storage has fallen ...

## Pros, Cons and Applications of Battery Energy Systems (BESS)

The use of large-scale battery systems raises safety concerns, including the risk of thermal runaway and fires. Robust safety measures and advancements in battery ...



## Knowledge base - Basis for Norway's battery stra

arket share in several parts of the battery value chain. The battery value chain has the potential to become a major new, profitable industry in Norway, giving us a chance to contribute to ...

## Techno-economic profitability of grid-scale battery storage ...

This study evaluates the techno-economic benefits of grid-scale battery storage allocation across 25 European countries, each with distinct wholesale price variation patterns.



## Contact Us

---

For catalog requests, pricing, or partnerships, please visit:  
<https://naturesnursery.co.za>