

## Global PV Storage Insights

# NMC battery storage tender price in Bolivia 2030



## Overview

---

6Wresearch actively monitors the Bolivia NMC Battery Pack Market and publishes its comprehensive annual report, highlighting emerging trends, growth drivers, revenue analysis, and forecast outlook.

6Wresearch actively monitors the Bolivia NMC Battery Pack Market and publishes its comprehensive annual report, highlighting emerging trends, growth drivers, revenue analysis, and forecast outlook.

Their global manufacturing capacity was forecast to grow from two to seven terawatt-hours from 2023 to 2030, China accounting for 60 percent of the total in the latter year. Lithium-ion chemistry is the most widespread in rechargeable battery cells, including nickel-manganese-cobalt-oxide (NMC).

The global EV NMC Battery Market was valued at USD 22.8 Billion in 2024 and is projected to reach USD 70.8 Billion by 2030, growing at a CAGR of 14.8% during the forecast period. The surge is fueled by rising electric vehicle (EV) adoption, government emission targets, and technological.

The Global NMC Lithium-Ion Battery Market Analysis Report is a comprehensive report with in-depth qualitative and quantitative research evaluating the current scenario and analyzing prospects in NMC Lithium-Ion Battery Market over the next eight years, to 2030. Robust changes brought in by the.

A study by McKinsey & Company highlights that EV sales are projected to rise from 4.5 million in 2021 to 28 million by 2030. This surge in demand could outpace the supply of these critical minerals, particularly cobalt and lithium. While advancements in mining technologies may boost lithium.

Nickel Manganese Cobalt (NMC) Battery Market Forecasts to 2030 - Global Analysis By Type (NMC 622, NMC 532 and NMC 111), Application (Commercial, Consumer Electronics, Electric Vehicles, Industrial, Residential and Other Applications) and By Geography According to Statistics MRC, the Global Nickel.

The Global NMC Lithium-Ion Batteries Market Size is estimated to register 15.5% growth over the forecast period from 2023 to 2030. The market growth is driven by an increasing integration of renewable energy sources like solar and wind power into the grid has created a demand for energy storage.

## NMC battery storage tender price in Bolivia 2030

---



### Lithium-Ion Battery Pack Prices See Largest Drop ...

New York, December 10, 2024 - Battery prices saw their biggest annual drop since 2017. Lithium-ion battery pack prices dropped 20% from 2023 to a record low of \$115 per kilowatt-hour, according to analysis by research provider ...

### Utility-Scale Battery Storage , Electricity , 2022 , ATB

The 2022 ATB represents cost and performance for battery storage across a range of durations (2-10 hours). It represents lithium-ion batteries (LIBs)--focused primarily on nickel manganese cobalt (NMC) and lithium iron ...



### BloombergNEF:

BloombergNEF's annual battery price survey finds prices fell 6% from 2020 to 2021, but rising commodity prices start to bite. Lithium-ion battery pack prices, which were above \$1,200 per kilowatt-hour in 2010, have fallen ...

### NMC Lithium-Ion Battery Market Outlook Report

The data and analysis assist our clients to plan procurement, identifying potential vendors/clients to associate with, understanding

NMC Lithium-Ion Battery price trends and patterns, and exploring new NMC Lithium-Ion Battery sales channels.



## Bolivia Battery Energy Storage Market (2024-2030)

Historical Data and Forecast of Bolivia Battery Energy Storage Market Revenues & Volume By Large Scale (Greater than 1 MW) for the Period 2020-2030 Bolivia Battery Energy Storage ...

## Nickel Manganese Cobalt (NMC) Battery Market Forecasts to 2030 ...

Nickel Manganese Cobalt (NMC) Battery Market Forecasts to 2030 - Global Analysis By Type (NMC 622, NMC 532 and NMC 111), Application (Commercial, Consumer ...



## Cost Projections for Utility-Scale Battery Storage: 2023 ...

Figure ES-2 shows the overall capital cost for a 4-hour battery system based on those projections, with storage costs of \$245/kWh, \$326/kWh, and \$403/kWh in 2030 and \$159/kWh, \$226/kWh, ...

## Nmc Vs Lfp: Comparing Two Leading Battery ...

Battery Technology Basics Understanding battery technology is crucial in the modern world. Batteries power everything from small gadgets to electric cars. They store energy efficiently and are vital for renewable energy ...



**TAX FREE**

**ENERGY STORAGE SYSTEM**

**Product Model**  
 HJ-ESS-215A(100KW/215KWh)  
 HJ-ESS-115A(50KW 115KWh)

**Dimensions**  
 1600\*1280\*2200mm  
 1600\*1200\*2000mm

**Rated Battery Capacity**  
 215KWH/115KWH

**Battery Cooling Method**  
 Air Cooled/Liquid Cooled

## Swedish thermal battery energy storage tender

A separate solar and storage project Scatec is building in South Africa, awarded to the firm through another procurement. Image: Scatec. Norway-based IPP Scatec has won preferred ...

## Global NMC Battery Material Supply, Demand and Key ...

The global NMC Battery Material market size is expected to reach \$ million by 2030, rising at a market growth of %CAGR during the forecast period (2024-2030). This report studies the ...



## NMC vs LFP vs LTO Batteries: EVs & Energy Storage ...

Compare NMC, LFP, and LTO batteries for EVs & energy storage. This guide covers energy density, safety, lifespan, and cost analysis for each battery type.

## LFP vs. NMC Batteries: Market Growth and Performance ...

5. Cycle Life: LFP Batteries Last Between 3,000-7,000 Cycles, Whereas NMC Batteries Typically Range Between 1,500-2,500 Cycles  
Battery lifespan is a key consideration for EV owners and ...



## Figure 1. Recent & projected costs of key grid

The "Report on Optimal Generation Capacity Mix for 2029-30" by the Central Electricity Authority (CEA 2023) highlight the importance of energy storage systems as part of ...

## Global battery demand to quadruple by 2030: Bain

Between 2023 and 2030, the demand for batteries worldwide is predicted to triple to 4,100 gigawatt-hours (GWh) due to the continued growth in sales of electric vehicles (EVs). Consequently, OEMs need to focus more ...



## Batteries for Stationary Energy Storage 2025-2035: ...

Batteries for Stationary Energy Storage 2025-2035: Markets, Forecasts, Players, and Technologies 10-year forecasts on Li-ion BESS. Analyses on players, project pipelines, grid-scale & residential BESS markets, technology trends & ...

## Wave of Decline Sweeps Lithium-Ion Battery Pack Pricing, in ...

Lithium-ion battery pack prices dropped 20% in 2024, reaching \$115/kWh. EV battery prices dip below \$100/kWh--explore the trends behind this decline.



## Prices of Lithium Batteries: A Comprehensive Analysis

How Have Lithium Battery Prices Trended Historically? From 2010-2023, average prices fell from \$1,200/kWh to \$139/kWh. However, 2022 saw a 7% price spike due to ...

## Bigger cell sizes among major BESS cost reduction ...

The scale of the reduction suggests that in addition to the falling cost of batteries--BNEF's recent Lithium-ion Battery Price Survey found that battery pack prices fell 20% year-on-year to 2024, again the biggest drop ...



## Lfp vs nmc battery, which one is better?

2 ???· Price Comparison In LFP vs NMC battery, LFP batteries are generally more cost-effective due to the abundance of iron and phosphate. In contrast, NMC batteries may incur higher costs due to the demand for nickel and cobalt, ...

## NMC vs LFP: What battery type is BEST for you?

The energy storage industry is growing rapidly, offering exciting opportunities for optimizing energy usage, lowering carbon footprints, and reducing costs. Among the various ...



## McKinsey: Is the 2030 Battery Supply Sustainable?

McKinsey reveals 2030 battery raw material outlook on lithium, nickel and cobalt as demand for these materials may soon outstrip base-case supply. The electrification of ...

## LFP vs. NMC: Which Solar Battery Chemistry Is Best for Your ...

Choosing between LFP and NMC batteries? Compare lifespan, cost, safety, sustainability, and performance to find the best home energy storage solution. Learn which battery chemistry suits ...



## Battery Material Shifts in the Li-ion Market

The lithium-ion (Li-ion) battery industry is undergoing significant shifts in material usage, driven by the growing demand for electric vehicles (EVs) and stationary battery storage applications. Despite some short-term concerns ...

## Nickel Manganese Cobalt (NMC) Battery Market Forecasts to ...

NMC batteries are a type of lithium-ion battery known for their high energy density, which makes them well-suited for various applications, including electric vehicles ...



## Battery price forecast 2024: How EV demand in China affects ...

How EV demand in China affects battery costs for US stationary storage projects Ben Campbell, Research Manager, Energy Storage

## Global battery demand to quadruple by 2030 and ...

SINGAPORE - July 17, 2024 - Global battery demand is expected to quadruple to 4,100 gigawatt-hour (GWh) between 2023 and 2030 as electric vehicle (EV) sales continue to rise.



## LFP vs NMC: Which is Better for Stationary Battery Energy Storage

Discover the key differences between LFP and NMC lithium-ion batteries in stationary energy storage systems. Learn which chemistry offers better safety, lifecycle value, ...

## Lithium-Ion Battery Pack Prices Hit Record Low of ...

BloombergNEF's annual battery price survey finds a 14% drop from 2022 to 2023 New York, November 27, 2023 - Following unprecedented price increases in 2022, battery prices are falling again this year. The price of ...



## Analyzing the Growth and Challenges of NMC Batteries

Explore the NMC battery future, addressing supply chain, sustainability, and market challenges while uncovering growth opportunities by 2030.

## Raw material cost , Storage Lab

In order to assess the impact of raw material price changes on product prices, it is important to understand the raw material composition of electricity storage technologies. Figure 2 illustrates this for lithium-ion battery packs by displaying ...

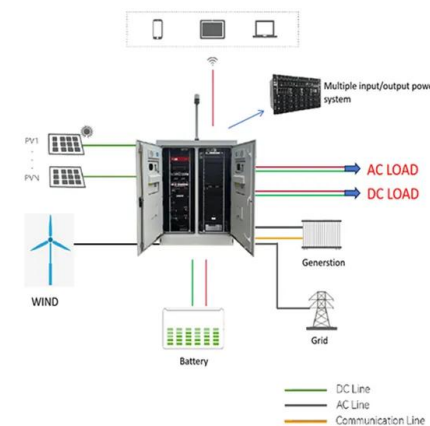

## The Price of 50 kWh Lithium Ion Batteries: A Comprehensive ...

The price of a 50 kWh lithium-ion battery can vary significantly based on multiple factors, including the type of lithium-ion chemistry, brand, quality, intended application, and ...

## Contact Us

---

For catalog requests, pricing, or partnerships, please visit:  
<https://naturesnursery.co.za>